

# INDUSTRIAL THERMOCOUPLES INDEX

	<b>PAGE</b>
General Information .....	I1
Straight Base Metal Thermocouple Elements (IA) .....	I2
Angled Base Metal Thermocouple Elements (IB) .....	I3
Noble Metal Thermocouple Elements (IC, ID) .....	I4
Metal Protection Tubes (IPM) .....	I5
Ceramic Protection Tubes (IPC) .....	I6
Metal Protection Tube Assemblies (IT, I1, I2, I4, I8) .....	I7
Ceramic Protection Tube Assemblies (IT, I1, I2, I4, I8) .....	I8

## General Information, Industrial Thermocouple Section

SensorTec's industrial thermocouples are used in high temperature applications, such as those listed below. Several calibrations are available as well as various mechanical configurations. Contact SensorTec for technical assistance in choosing the correct industrial thermocouple for your application.

From standard insulated elements to complete noble metal thermocouple assemblies, SensorTec can provide temperature sensors for your high temperature applications.

Please contact SensorTec for availability of additional industrial thermocouple configurations.

### Applications:

- Metal processing
- Heat treating
- Refineries
- Glass manufacturing
- Semiconductor manufacturing

# STRAIGHT BASE METAL THERMOCOUPLE ELEMENTS

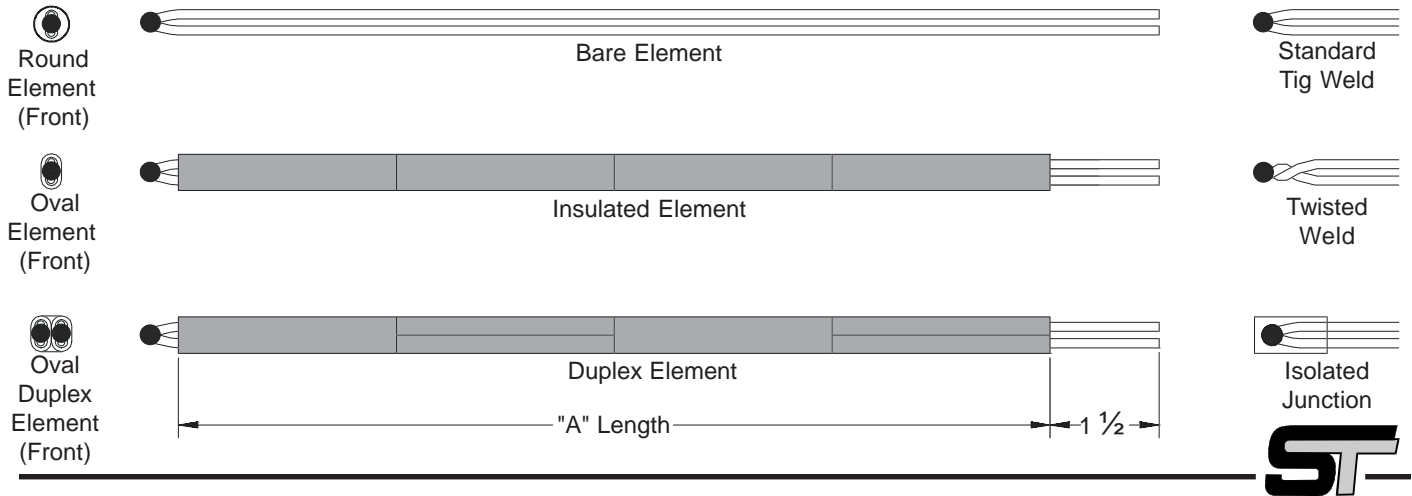

SENSOR STYLE	
A	Straight Base Metal T/C
CALIBRATION	
J	Type "J"
K	Type "K"
TYPE/OPTION	
0	Single Element
4	Duplex Element
JUNCTION TYPE	
S	Standard Tig Weld
T	Twisted Weld
I	Isolated

ELEMENT LENGTH ("A")	
12	= 12 Inches
18	= 18 Inches
24	= 24 Inches
30	= 30 Inches
36	= 36 Inches
--	= Specify other lengths
Note: Actual cut length will be 1 1/2" longer than specified to allow for terminal connections.	

INSULATOR TYPE	
N	= None
R	= Round
O	= Oval

CONDUCTOR GAUGE	
14	= 14 AWG
11	= 11 AWG
08	= 8 AWG

ELEMENT INSULATION CHART				
Order Code	Insulation Description	Wire Gauge	Insulator Dimension	
			Single	Duplex
N	Bare Element	---	None Used	None Used
R	Round Ceramic	14 Ga.	.250 OD	.320 OD
		11 Ga.	.465 OD	---
		8 Ga.	.465 OD	---
O	Oval Ceramic	14 Ga.	.313 x .188	.436 x .436
		11 Ga.	.375 x .218	.436 x .436
		8 Ga.	.500 x .286	.572 x .572

SensorTec insulated elements are supplied with refractory insulators 2380° Deg F maximum temperature

SensorTec's straight base metal thermocouple elements are available as both part of a complete Industrial Thermocouple Assembly or as a separate replacement element for existing assemblies. The replacement elements are available with or without ceramic insulators and other listed options.

# ANGLED BASE METAL THERMOCOUPLE ELEMENTS

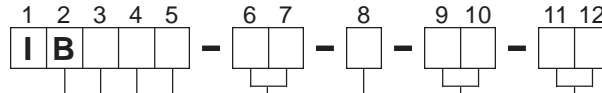
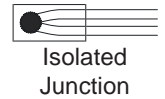
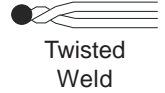
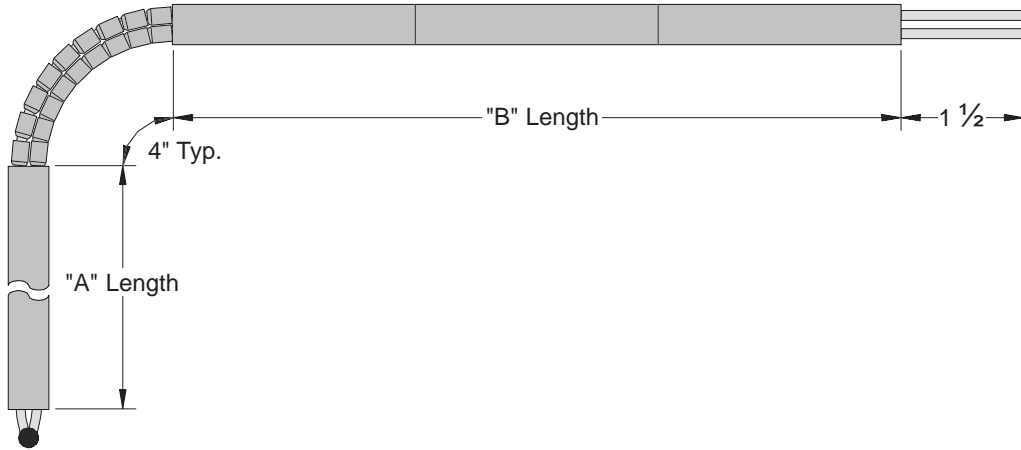

SENSOR STYLE	
B	= Angled Base Metal T/C

CALIBRATION	
J	= Type "J"
K	= Type "K"

TYPE/OPTION	
0	= Single Element
4	= Duplex Element

JUNCTION TYPE	
S	= Standard Tig Weld
T	= Twisted Weld
I	= Isolated

COLD LENGTH ("B")	
12	= 12 Inches
18	= 18 Inches
24	= 24 Inches
30	= 30 Inches
36	= 36 Inches
--	= Specify other lengths

HOT LENGTH ("A")	
12	= 12 Inches
18	= 18 Inches
24	= 24 Inches
30	= 30 Inches
36	= 36 Inches
--	= Specify other lengths

INSULATOR TYPE	
N	= None
R	= Round
O	= Oval

CONDUCTOR GAUGE	
14	= 14 AWG
11	= 11 AWG
08	= 8 AWG

# NOBLE METAL THERMOCOUPLE ELEMENTS

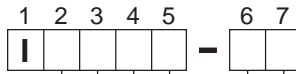
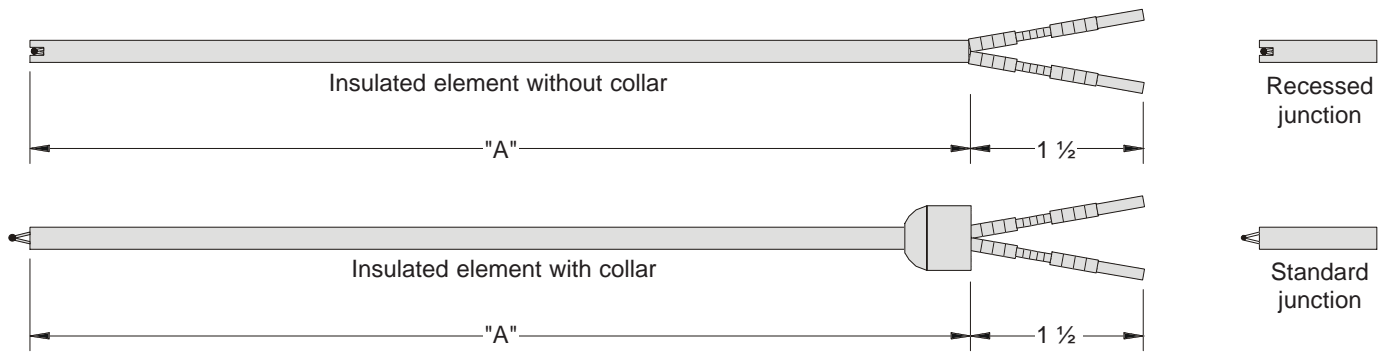

SENSOR STYLE
C = Insulated Element w/ Collar
D = Insulated Element w/o Collar <sup>1</sup>

CALIBRATION
R = Type "R" Pt \ Pt & 13% Rh
S = Type "S" Pt \ Pt & 10% Rh
B = Type "B" Pt & 30% Rh \
Pt & 6% Rh
C = Type "C" Tg & 5% Rh \
Tg & 26% Rh

TYPE/OPTION
0 = Single Element
4 = Duplex Element

JUNCTION TYPE
S = Standard
I = Isolated\Recessed

ELEMENT LENGTH "A"
12 = 12 Inches
18 = 18 Inches
24 = 24 Inches
30 = 30 Inches
36 = 36 Inches
-- = Specify other lengths

SensorTec's noble metal thermocouple elements are available as both, part of a complete high temperature Industrial Thermocouple Assembly or as separate replacement elements for existing assemblies. The replacement elements are constructed with high temperature alumina insulators.

<sup>1</sup> Style "ID" available only as Isolated\Recessed Junction

# METAL PROTECTION TUBES

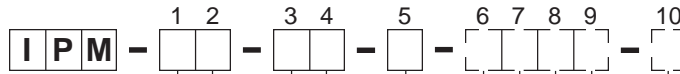
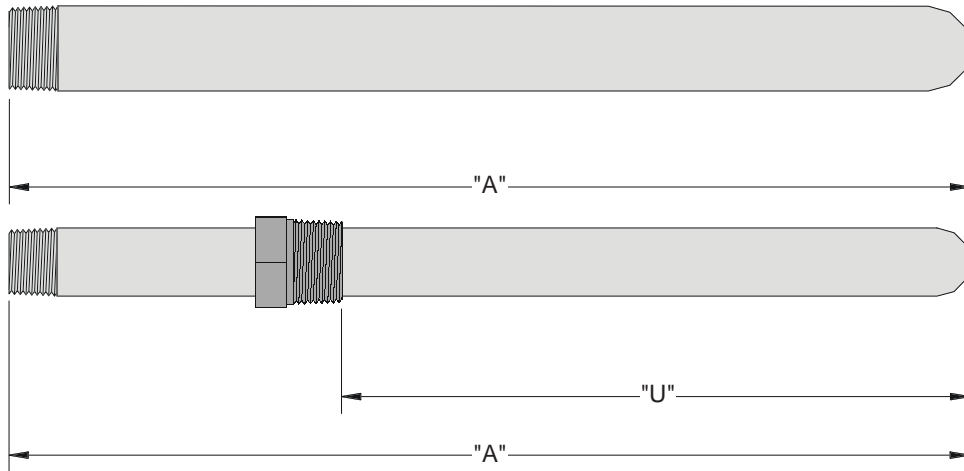

PROTECTION TUBE SIZE
B = 1/4" NPT Pipe
D = 1/2" NPT Pipe
E = 3/4" NPT Pipe
F = 1" NPT Pipe

PROTECTION TUBE TYPE
A = Schedule 40 - Standard

PROTECTION TUBE OPTIONS
F = adj. steel mounting flange

HOT LENGTH FOR BUSHING "U"
Length in whole inches ex 12 = 12 Inches

WELDED BUSHING MATERIAL
D = Carbon Steel
T = 304 SST
W = 316 SST

OPTIONAL WELDED BUSHING
D = 1/2" NPT Bushing
E = 3/4" NPT Bushing
F = 1" NPT Bushing
G = 1 1/4" NPT Bushing
H = 1 1/2" NPT Bushing
Note: Welded bushing must be at least one NPT size larger than protection tube size.

PROTECTION TUBE MATERIAL
D = Carbon Steel
K = Inconel 601
S = 446 SST
T = 304 SST
W = 316 SST

PROTECTION TUBE LENGTH "A"
Whole inches of tube

# CERAMIC PROTECTION TUBES

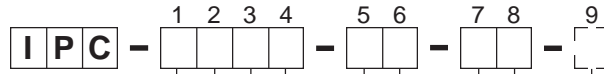
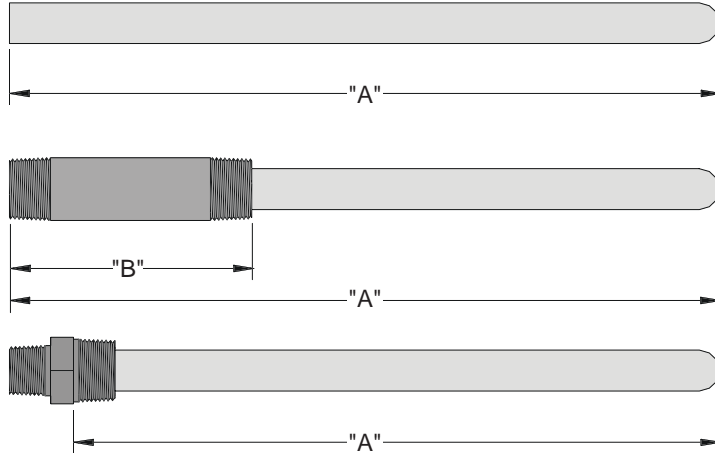

MOUNTING FITTING TYPE
1 = None
2 = Pipe Nipple
3 = Hex Fitting

MOUNTING FITTING LENGTH "B"
For Pipe Nipple - length in inches ex. 4" nipple = 04
Mounting fitting types 1 & 3 = 00

MOUNTING FITTING MATERIAL
D = Carbon Steel
T = 304 SST
W = 316 SST
Mounting fitting type 1 = 0

OPTIONS
F = adj. steel mounting flange

PROTECTION TUBE LENGTH "A"
Whole inches of tube

PROTECTION TUBE MATERIAL
A = Alumina
M = Mullite

PROTECTION TUBE SIZE
Single tube design
A = 1/4" ID x 3/8" OD
B = 7/16" ID x 11/16" OD
C = 1/2" ID x 3/4" OD
D = 3/4" ID x 1" OD
E = 1" ID x 1 1/4" OD
Dual tube design
F = 1/4" ID x 11/16" OD
See table below for dimesions

Tube Part#	Tube Size		Pipe Nipple Size	Hex Nipple	Hex Nipple
	ID	OD		Process	Termination
A	1/4"	3/8"	1/2" NPT	-	-
B	7/16"	11/16"	3/4" NPT	3/4" NPT	1/2" NPT
C	1/2"	3/4"	3/4" NPT	3/4" NPT	1/2" NPT
D	3/4"	1"	1 1/4" NPT	1 1/4" NPT	1" NPT
E	1"	1 1/4"	1 1/4" NPT	1 1/4" NPT	1" NPT
F	1/4"	11/16"	3/4" NPT	3/4" NPT	1/2" NPT

# METAL PROTECTION TUBE ASSEMBLIES

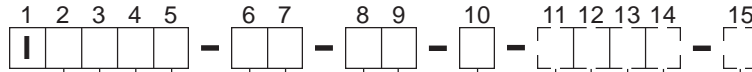
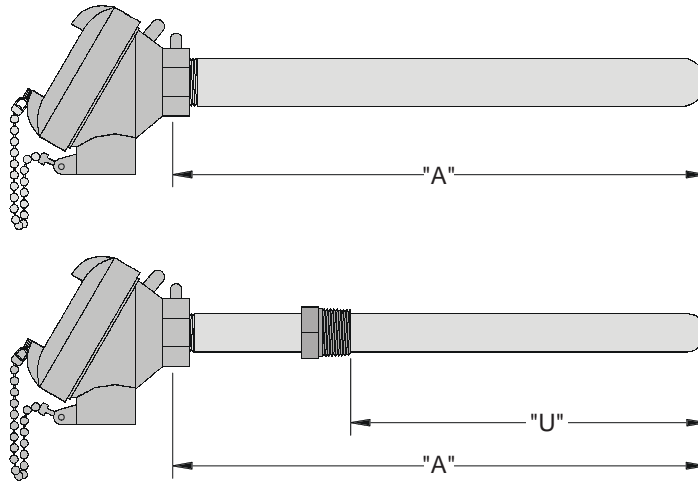

SENSOR STYLE	
<b>Snap Cover style</b>	
T	Cast Aluminum Weatherproof
4	Din "B" Size Aluminum WP
<b>Screw Cover style</b>	
1	Cast Aluminum Weatherproof
2	Cast Iron Weatherproof
8	Stainless Steel Weatherproof

CALIBRATION	
J	Type "J"
K	Type "K"

TYPE/OPTION	
0	Single Element
4	Duplex Element

JUNCTION TYPE	
S	Standard Tig Weld
T	Twisted Weld
I	Isolated

PROTECTION TUBE SIZE	
B	1/4" NPT Pipe
D	1/2" NPT Pipe
E	3/4" NPT Pipe
F	1" NPT Pipe

PROTECTION TUBE TYPE	
A	Schedule 40 - Standard

PROTECTION TUBE OPTIONS	
F	Adj. Steel Mounting Flange
G	Internal ground screw
M	MgO Style Element (Industrial style standard)
I	Stainless Steel Tag

HOT LENGTH FOR BUSHING "U"	
Length in whole inches ex 12 = 12 INCHES	

WELDED BUSHING MATERIAL	
D	Carbon Steel
T	304 SST
W	316 SST

OPTIONAL WELDED BUSHING	
D	1/2" NPT Bushing
E	3/4" NPT Bushing
F	1" NPT Bushing
G	1 1/4" NPT Bushing
H	1 1/2" NPT Bushing
Note: Welded bushing must be at least one NPT size larger than protection tube size.	

PROTECTION TUBE MATERIAL	
D	Carbon Steel
K	Inconel 601
S	446 SST
T	304 SST
W	316 SST

PROTECTION TUBE LENGTH "A"	
Whole inches of tube	

# CERAMIC PROTECTION TUBE ASSEMBLIES

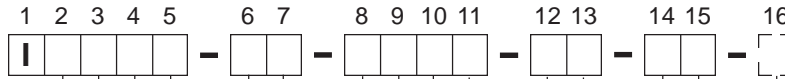
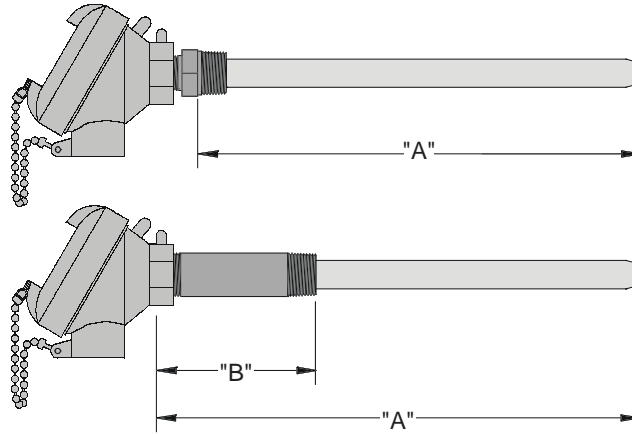

SENSOR STYLE	
<b>Snap Cover style</b>	
T	Cast Aluminum Weatherproof
4	Din "B" Size Aluminum WP
<b>Screw Cover style</b>	
1	Cast Aluminum Weatherproof
2	Cast Iron Weatherproof
8	Stainless Steel Weatherproof

CALIBRATION	
<b>Base Metal</b>	<b>Available Gauge</b>
K = Type "K"	8, 11, 14, 20 AWG
<b>Noble Metal</b>	<b>Available Gauge</b>
R = Type "R"	24 AWG, 26 AWG
S = Type "S"	24 AWG, 26 AWG
B = Type "B"	24 AWG

TYPE/OPTION
0 = Single Element
4 = Duplex Element

JUNCTION TYPE
S = Standard Tig Weld
T = Twisted Weld
I = Isolated

CONDUCTOR GAUGE
Select available gauge size for T/C from Calibration chart above example 8 AWG = 08

MOUNTING FITTING TYPE
2 = Pipe Nipple
3 = Hex Fitting

MOUNTING FITTING SIZE "B"
For Pipe Nipple - length in inches ex. 4" nipple = 04
Mounting fitting type 3 = 00

OPTIONS
G = Internal ground screw
F = Adjustable Steel Flange
I = Stainless Steel Tag

PROTECTION TUBE LENGTH "A"
Whole inches of tube

PROTECTION TUBE MATERIAL
A = Alumina (1870°C / 3400°F)
M = Mullite (1500°C / 2700°F)

PROTECTION TUBE SIZE
<b>Single tube design</b>
A = 1/4" ID x 3/8" OD
B = 7/16" ID x 11/16" OD
C = 1/2" ID x 3/4" OD
D = 3/4" ID x 1" OD
E = 1" ID x 1 1/4" OD
<b>Dual tube design</b>
F = 1/4" ID x 11/16" OD

MOUNTING FITTING MATERIAL
D = Carbon Steel
T = 304 SST
W = 316 SST

Tube Part#	Tube Size		Pipe Nipple Size	Hex Nipple	Hex Nipple
	ID	OD		Process	Termination
A	1/4"	3/8"	1/2" NPT	-	-
B	7/16"	11/16"	3/4" NPT	3/4" NPT	1/2" NPT
C	1/2"	3/4"	3/4" NPT	3/4" NPT	1/2" NPT
D	3/4"	1"	1 1/4" NPT	1 1/4" NPT	1" NPT
E	1"	1 1/4"	1 1/4" NPT	1 1/4" NPT	1" NPT
F	1/4"	11/16"	3/4" NPT	3/4" NPT	1/2" NPT