

Q9



Basic Programmable 2-wire Transmitter



Q9 is a basic, programmable non-isolated, easy-to-use 2-wire transmitter. The Low Profile housing has a height of only 18.5 mm / 0.72 inch. Configuration is made in seconds with the user friendly Windows software. No external power supply required for configuration. The transmitter is programmable for RTD's in 3- and 4-wire connection according to different standards as well as for 11 T/C types. Useful error correction functions improve the accuracy.

- Robust terminals with test connections
- Only 18.5 mm / 0.72 inch high
- Accepts RTD in 3- and 4-wire connection and 11 T/C types
- Temperature linear output
- Sensor error and system (sensor/transmitter) error correction for highest total accuracy
- Configuration without external power
- Easy-to-use Windows configuration software
- NAMUR compliant
- Rugged design tested for 10 g vibrations
- USB communication

Specifications:

Input RTD	3-, 4-wire connection
Pt100 ($\alpha=0.00385$) ¹⁾	-200 to +1000 °C / -328 to +1832 °F
Pt1000 ($\alpha=0.00385$) ¹⁾	-200 to +200 °C / -328 to +392 °F
PtX $10 \leq X \leq 1000$ ($\alpha=0.00385$) ¹⁾	Upper range depending on X-value
Pt100 ($\alpha=0.003902$)	-200 to +1000 °C / -328 to +1832 °F
Pt100 ($\alpha=0.003916$)	-200 to +1000 °C / -328 to +1832 °F
Ni100 ²⁾	-60 to +250 °C / -76 to +482 °F
Ni1000 ²⁾	-10 to +150 °C / +14 to +302 °F
Ni120 ³⁾	-70 to +300 °C / -94 to +572 °F
Cu10 ⁴⁾	-200 to +260 °C / -328 to +500 °F
Input Thermocouples	
Types	B, C, E, J, K, L, N, R, S, T, U
Sensor failure	Upscale, downscale or off
Adjustments - Zero	Any value within range limits
Adjustments - Minimum spans	
Pt100, Pt1000, Ni100, Ni1000	10 °C / 18 °F
T/C	2 mV
Output	4-20 mA, temperature linear
Operating temperature	-40 to +85 °C / -40 to +185 °F
Galvanic isolation	No
Power supply	8 to 32 VDC
Typical accuracy	±0.15 % of temperature span
Connection head	DIN B or larger

¹⁾IEC 60751, ²⁾DIN 43760, ³⁾Edison No.7, ⁴⁾Edison No.15

Input connections

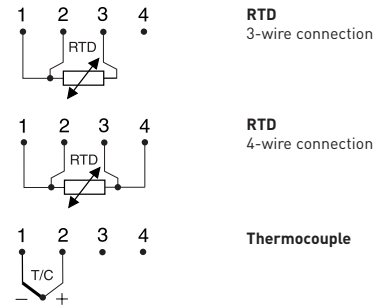

Output connections

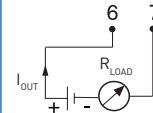

Output load diagram

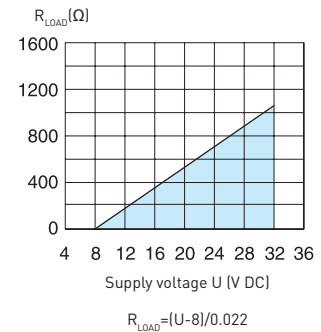

Dimensions

